

PX0597/WH Datasheet

Product Name // Straight Female IEC Connector PX0597
Series White Screw Terminals EN60 320-1 Standard Sheet
C15 and C16 Class I

 [View Product Page](#)

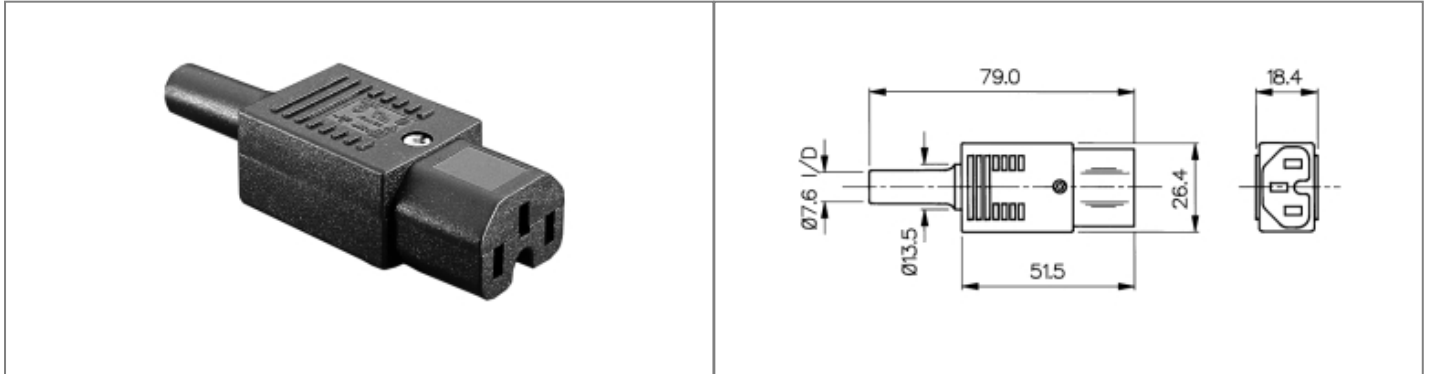

// Product Description:

-  Straight Female IEC Connectors
-  EN60 320-1 Standard Sheet C15 and C16 Class I
-  Hot Condition
-  Cable mount
-  Screw Terminals (rewireable)
-  Choice of colour, depending on part code suffix: /WH - White, /GY - Grey, no suffix - Black (some approvals apply to specific colours only - see data for details)
-  Mate with PX0590, PX0595

// General Information:

Product Display Title:	Straight Female IEC Connectors
Product Family:	IEC Connectors
Product Series:	IEC60320 Main Inlets and Outlets
Approvals:	CSA, ENEC, UL, VDE, RCM
Body Material:	Nylon 66
Current Max:	10A
Flamability Rating:	UL94V-0
Function:	Straight Female Connector
iec Connector Colour:	White
iec Connector Mates With:	PX0590,PX0595
iec En60620 Type:	EN60 320-1 Standard Sheet C15 and C16 Class I
Max Operating Temperature:	+70°C
Min Operating Temperature:	-40°C
Number Of Contacts:	3 Contacts
Rohs Compliant:	Yes
Voltage Max:	250V

// Product PDF Links

 [IEC Connectors product data](#)

 [PX0587, PX0587/SE, PX0588, PX0597...](#)

// Product 3D CAD Model Links

 [PX0597/WH3D CAD Model](#)

// Product Certificate Links

 [VDE Certificate - P587, P597](#)

 [VDE Certificate - P587, P597 - CB](#)