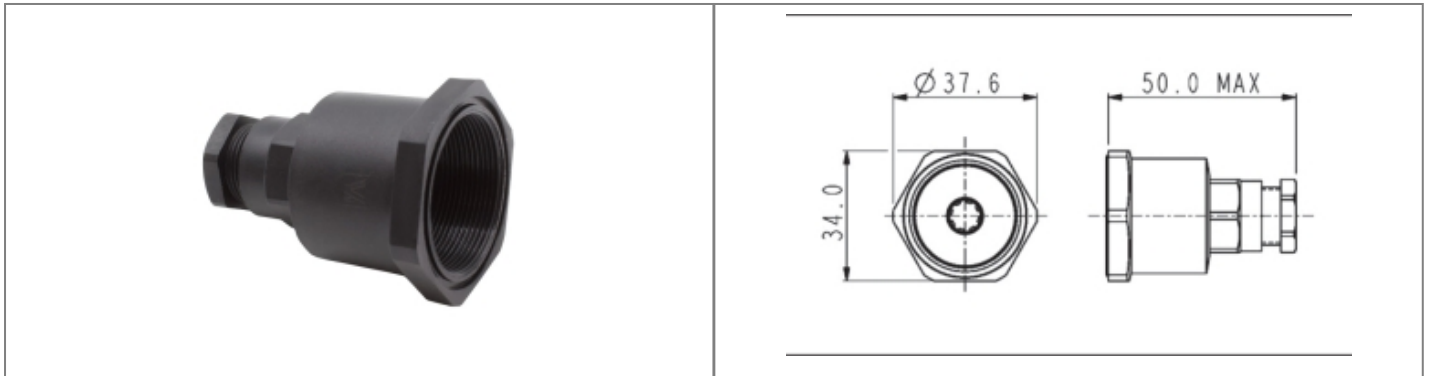

PXV0799/04 Datasheet

Product Name // Vitalis Buccaneer Rear Of Panel Shell Range

[View Product Page](#)

// Product Description:

- ⬢ PXV0799/04 provides a PCF reduction of 8.9 kg CO₂e per 100 units compared to the equivalent Standard Series Buccaneer part number
- ⬢ Rear of Panel Back Shell
- ⬢ Compatible with Standard Vitalis Series (PXV) and Standard Series (PX) Buccaneer Front Panel Mount Connectors
- ⬢ Replaces front panel mounting nut, providing an environmental seal to the rear of the panel
- ⬢ 3.5mm-5mm diameter cable acceptance
- ⬢ Cable Glands for differing cable diameters available separately individually or in packs
- ⬢ Cable Support accessory 12237/R available separately

// General Information:

Product Display Title:	Vitalis Buccaneer Rear Of Panel Shell Range
Product Family:	Circular Power Connector
Product Series:	Standard Vitalis Buccaneer
Body Colour:	Black
Body Material:	Polyamide (PA)- Glass Filled
Body Material Type:	Plastic Body
Coupling Type:	Screw
Diameter Over Coupling Ring Mm:	38.1mm
Flamability Rating:	UL94HB
Function:	Accessory
Ip Rating:	IP68
Max Cable Entry Size:	5mm
Min Cable Entry Size:	3.5mm
Max Operating Temperature:	+70°C
Min Operating Temperature:	-20°C
Rohs Compliant:	Yes

// Product PDF Links

[Standard Vitalis Buccaneer Product...](#)

// Product 3D CAD Model Links

[PXV0799/043D CAD Model](#)